



0201282 / BM211 – 0201284 / BM21S
0201283 / BM242 – 0201285 / BM24S
Plastic bottle traps **EASYPHON**



FUNCTION :
Designed to stop bad smell with a water seal

DESCRIPTION :

- Water trap with built-in seal
- Water trap with adjustable height for washbasin or bidet
- Base trap removable

TECHNICAL FEATURES :

Material :

- Body and gaskets : co-injected polypropylene and elastomere

Dimensions :

- Inlet connection : G 1”1/4
- Adjustable height : 133 – 192 mm
- Water seal : 50 mm

Performances :

- Withstand a 90°C temperature
- Flow rate under a 120 mm water height (table below)

MAINTENANCE :

- Use a non aggressive cleaner and a soft cloth

STANDARDS :

- Complies with NF EN 274

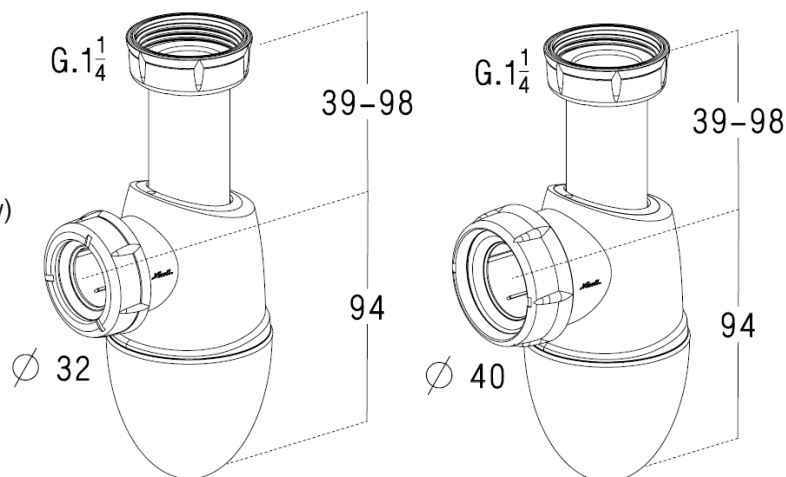

CODE NUMBER	OUTLET mm	FLOW RATE l/min	PACKAGING
0201282 / BM211	Ø 32	50	HEAT-RETRACTABLE CUFF
0201284 / BM21S	Ø 32	50	PLASTIC BAG
0201283 / BM242	Ø 40	54	HEAT-RETRACTABLE CUFF
0201285 / BM24S	Ø 40	54	PLASTIC BAG

MARCH 2021



Head office and Plants: 37, rue Pierre & Marie Curie
BP 10966 - 49309 Cholet Cedex - FRANCE
Phone + 33 (0)2 41 63 73 83
Email: export.nicoll@alixis.com

an Aliaxis company