



0701107/1700 0791107/1700Y 0701108/1700S 0701122/1720P

Back pressure float valve

FUNCTION :

- Float valve for toilet cistern with lateral arrival

TECHNICAL SPECIFICATIONS :

Material :

- Body : POM
- Membrane : SILICONE
- Connection : BRASS

Dimensionnal charateristics :

- Footprint : height-adjustable = 190 to 290 mm / width = 50 mm / depth = 110 mm

Operating charateristics :

- Operational pressure range : 0,5 bar -> 10 bar
- Soft closing without hammer effect (< 2 bar)
- Back-flow protection with air vent to prevent back siphonage
- Acoustic perform class II (20 dBA < Lap ≤ 30 dBA)



REFERENCES	CONNECTION	PACKAGING
0701107 / 1700	G 3/8" (brass)	Carton box
0791107 / 1700Y	G 3/8" (brass)	Clear box
0701108 / 1700S	G 3/8" (brass)	Plastic bag
0701122 / 1720P	G 1/2" (polyamide)	Plastic bag

STANDARDS / CERTIFICATION :

- NF EN 141214
- Health attestation (ACS)

ACCESSORIES :

Screwing nut and tightness seal with filtration grid supplied

INSTALLATION :

Piping network will be cleaned before float valve installation.

Telescopique part will be adjust at the cistern bottom to lead up water.

Float height will be adjust to maintain air gap ≥ 20 mm between water level and overflow hole.

MAINTENANCE :

Add a glass of white vinegar regularly on the cistern to remove scale deposite.

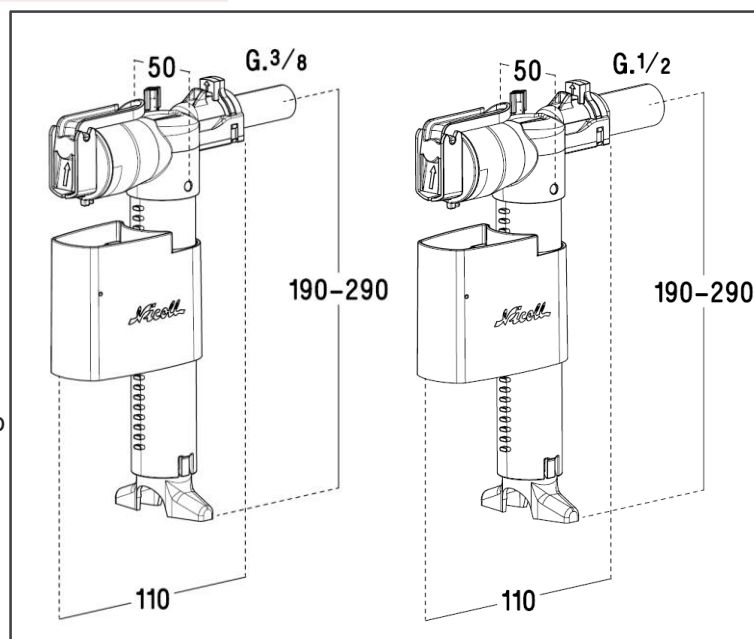

MAY 2019



Nicoll

Siège Social : 37, rue Pierre & Marie Curie
BP 10966 - 49309 Cholet Cedex
Téléphone : 33 (0)2 41 63 73 25
Fax : +33 (0)2 41 63 73 23
Email: tech-com.nicoll@alixis.com

— an Aliaxis company